



CI/SfB L519 + L529

Xh4

eltherington
architectural solutions
Innovation | Performance | Facades

Modular / Offsite

M1



Specification guide

Specification guide

Benefits

- Full bespoke capabilities
- 50 year manufacturing heritage
- Made in the UK
- Wide range of products, materials and finishes
- Low maintenance
- Does not support combustion and can meet the requirements laid out in BS476 Part 7. Class O non-combustible. BS EN 13501-1.

Modular / Offsite

As a leading supplier in the portable and modular building industry for many decades, Eltherington is committed to offering consistently reliable, innovative products of the highest quality.

We are able to supply a range of ancillary products for both internal and external applications, including:

- PVCu windows and doors
- Integrated window shutters (insulated and un-insulated)
- Screens, Grills and Louvres
- Safety and security products
- Modular canopies
- Specialist / bespoke fabrications

Our wide range of products and solutions are particularly suited for the manufacture of modular buildings including system-built, framed and off-site constructions.

All solutions offered by Eltherington for the modular sector are dry-fix and therefore meet the requirements for modern methods of construction.

A commitment to delivering consistently reliable, innovative products of the highest quality has established us as one

of the leading suppliers to the industry.

Innovation and service

Eltherington has been providing innovative architectural solutions to the construction industry for over 50 years. Our 6 acre, state of the art production facility allows us to take on board specialist architectural metal work projects of any scale. We fabricate a wide range of external architectural systems including Bull Noses, Fascias, Guttering, Rainscreen Cladding and Column Casings.



CPD

Eltherington offer RIBA accredited CPD seminars that can be presented to you or your team on request.

Technical support

Whatever product you are looking to specify, our skilled technical team will be able to provide you with support and advice at all stages of the project. We offer a full suite of 2D and 3D design packages.

Compliance

Our UK-based manufacturing facilities work to exacting tolerances to help you meet Building Regulation requirements. We are proud to be accredited to:
BS EN ISO 9001:2008 - Quality
BS EN ISO 14001:2004 - Environmental
OHSAS 18001:2007 - Health & Safety



Internal cladding



Cladding plank



Canopies



Specialist fabrications



Fascia and soffits



Windows and doors



Column casings

Fascia / Top Detail

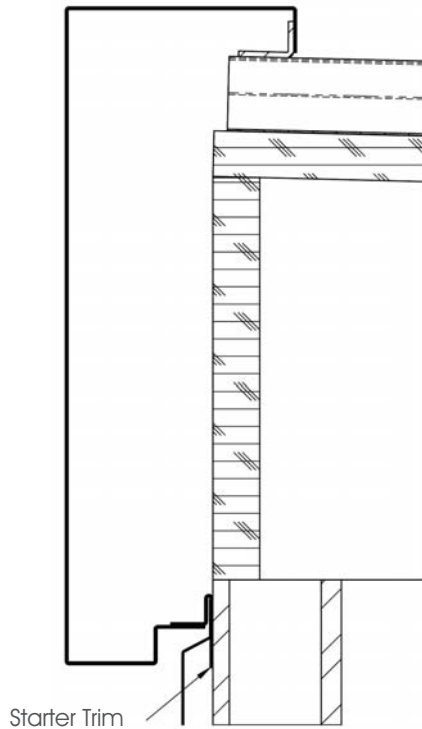

Window Head Detail

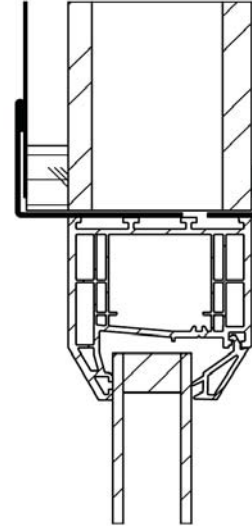

External Corner Detail

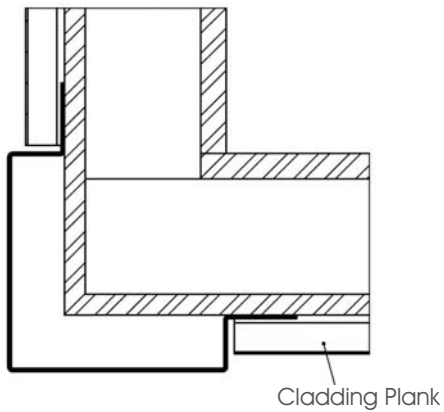

Window Jamb Detail

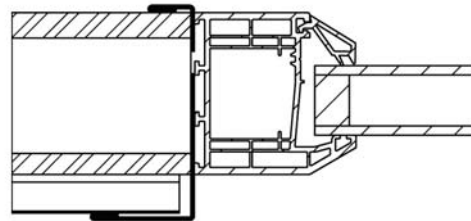

Bottom Detail

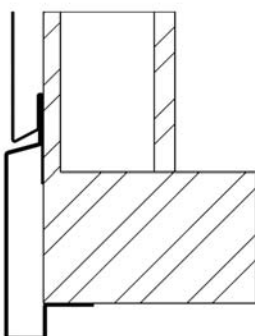

Window Cill Detail

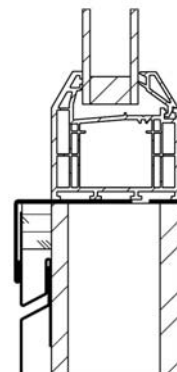

Specification guide

Horizontal Detail

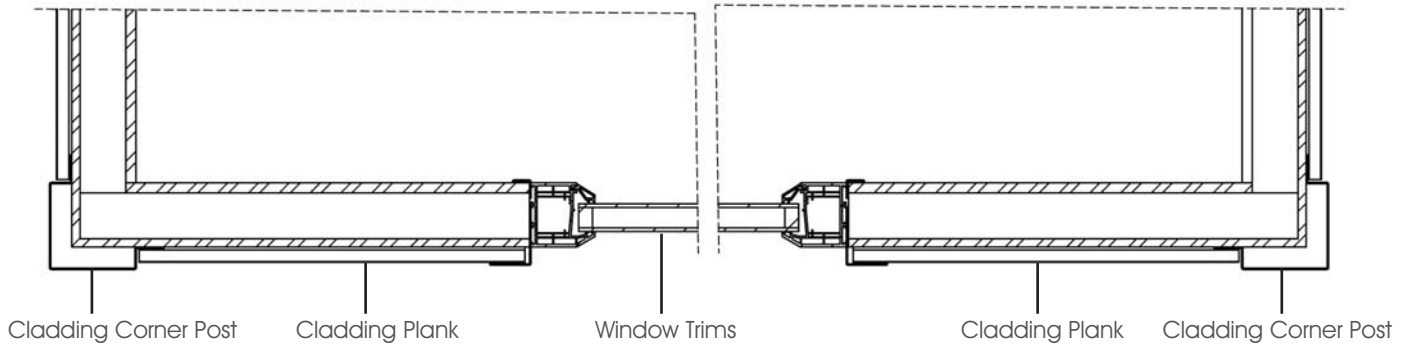

Simple interlocking Cladding Plank System

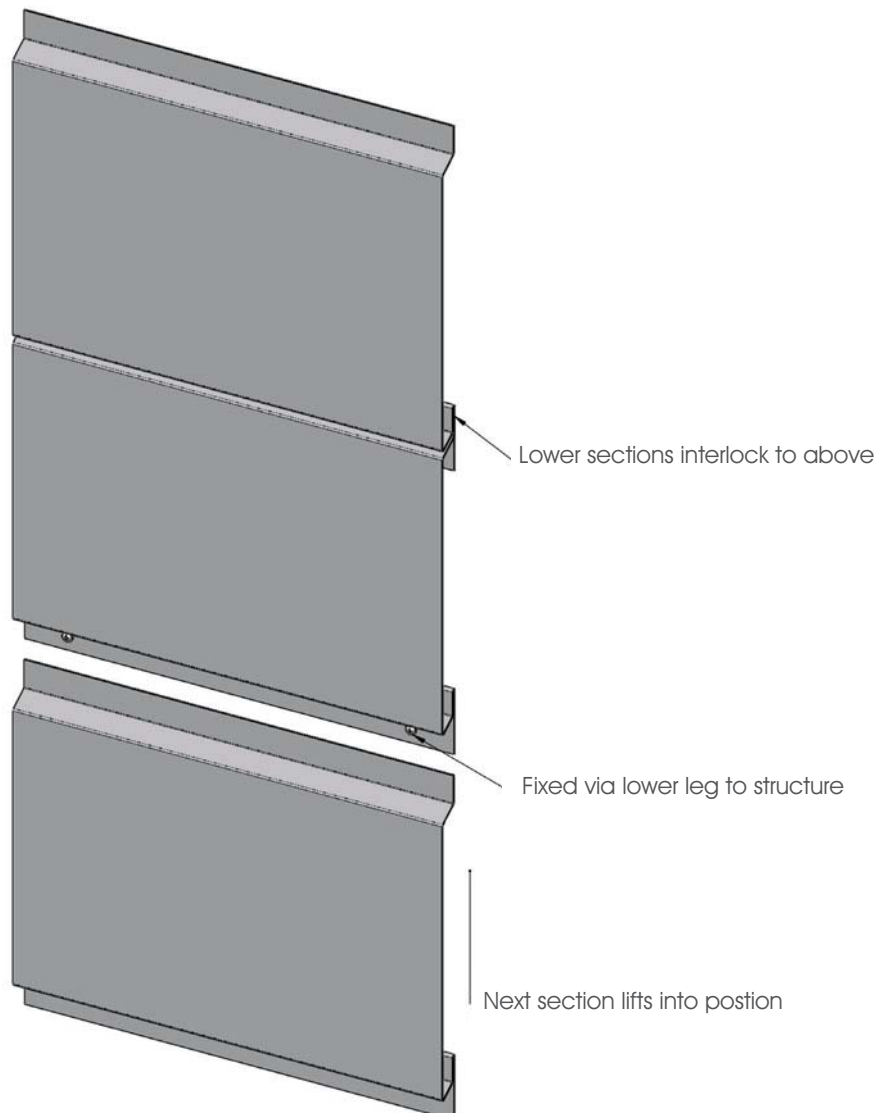

Specification guide

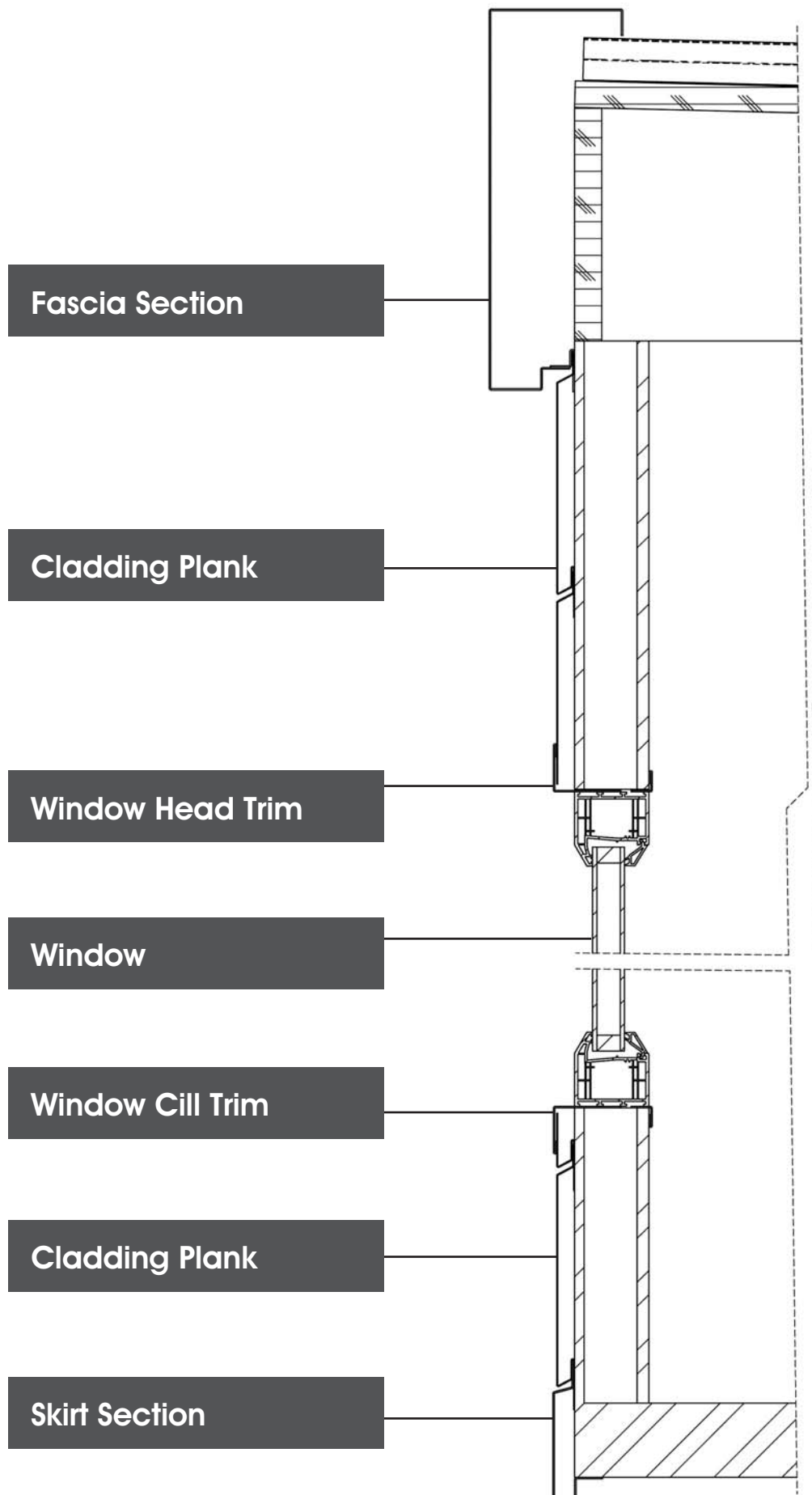

Modular / Offsite

Materials and finishes

Aluminium	Finish
Polyester powder coated	Standards
Polyester powder coated	Metallic & textured
Pre-coat	Standards
Pre-coat	Metallic & Chameleon
Anodised	Natural
Anodised	Anolok bronze
Anodised	Anolok black
Anodised	Anolok Blue Grey
Anodised	Anolok gold
Natural plain	Mill finish
Aluminium composite (ACM)	Reynobond
Aluminium	Rimex
Various	Perforated
Various	Slotted

Stainless Steel	Finish
304 / 14301	Satin polished
316 / 14401	Satin polished
Industrial	Shot peened/blasted
Unique	Circular polish
Natural plain	2B mill finish
Pattern	Rimex
Industrial	Granex
Arcelor Mittal	Uginox TT
Various	Perforated
Various	Slotted

Steel	Finish
Galvanised	PPC
Galvanised natural plain	Mill finish
Zinc	PPC
Zinc natural plain	Mill finish
Pre-coat	Dobel Plastisol
Mild steel	PPC
Corten steel natural plain	Mill finish
Various	Perforated
Various	Slotted

Other	Finish
Rimex Colourtex	Various
Rimex S/S Vortex	Various
Copper natural plain	Mill finish
Aluminium pre-coat Reynolux	Various
Zinc material	Mill finish
Aluminium pre-coat zinc	Grey
Aluminium pre-coat FF2	PVDF coated
Brass	Polished

Sustainability

Eltherington is committed to sustainable manufacturing leadership in all areas of its business, including recycling, reduction of waste and saving energy.

Showroom

Eltherington has a large showroom at our manufacturing site in Hull, East Yorkshire, showcasing all of our architectural solutions. To arrange a visit, please call us on 01482 320336.

Design assistance

Our team can assist you in all aspects of regulatory compliance covering fire safety, condensation and ventilation.

Along with our standard range of modular systems we can manufacture to your exact designs. We offer a full installer support programme.

Our commitment

Eltherington is at the forefront of innovation and performance in the modular sector. This gives customers confidence in our products, allowing them to realise their vision of creating buildings where people want to live and work.



Eltherington rainscreen cladding solutions have been independently tested and accredited to the specific requirements of CWCT.

The Centre for Window and Cladding Technology (CWCT) is the leading provider of information in the area of building envelopes and glazing. The CWCT establishes industry standards and provides guidance to its members.



Full NBS specifications are available for all Eltherington rainscreen cladding solutions. We have an experienced technical team that can assist you in putting together designs and detailed specifications.



Eltherington offers RIBA-assessed, high-quality CPD seminars at your office or regional centres around the UK. Please contact our customer services department for more information.

Other solutions available from Eltherington:



Column casings



Roofline



Rainscreen cladding



Internal cladding



Specialist fabrications



eltherington
architectural solutions
Innovation | Performance | Facades



Eltherington Aluminium Ltd, Dansom Lane South, Hull, East Yorkshire, HU8 7LA
T: 01482 320336 F: 01482 329956 E: info@Eltherington.co.uk